

(No Model.)

C. A. LIEB.  
TOOL POST FOR LATHES.

No. 272,277.

Patented Feb. 13, 1883.

Fig. 1.

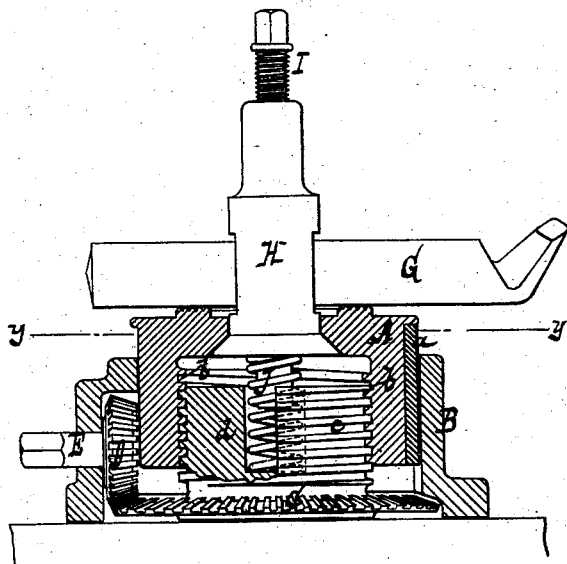
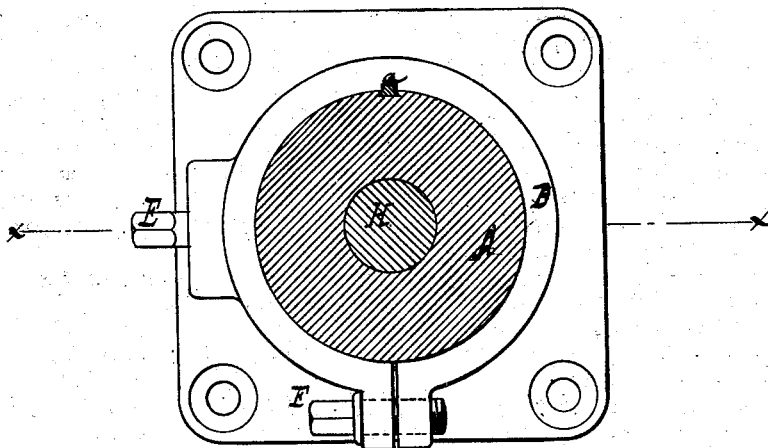

Fig. 2.



WITNESSES:

*Otto Aufeland*  
*William Miller*

INVENTOR

*Charles A Lieb*

BY *Van Bentwood & Hauck*

ATTORNEYS

# UNITED STATES PATENT OFFICE.

CHARLES A. LIEB, OF NEW YORK, N. Y.

## TOOL-POST FOR LATHES.

SPECIFICATION forming part of Letters Patent No. 272,277, dated February 13, 1883.

Application filed August 2, 1882. (No model.)

*To all whom it may concern:*

Be it known that I, CHARLES A. LIEB, a citizen of the United States, residing at New York, in the county and State of New York, have invented new and useful Improvements in Tool-Posts for Lathes, of which the following is a specification.

This invention relates to an improved mechanism for raising and lowering the tool-post of a lathe, said mechanism being so constructed that the tool can be raised and lowered conveniently while it is in operation.

The peculiar construction of my new mechanism is pointed out in the following specification.

In the accompanying drawings, Figure 1 represents a vertical central section in the plane *xx*, Fig. 2. Fig. 2 is a horizontal section in the plane *yy*, Fig. 1.

Similar letters indicate corresponding parts.

In these drawings, the letter A designates the tool-post, which is fitted to work up and down without lateral play in a socketed stand, B, said tool-post being provided with a feather-key, *a*, which engages with a seat in the interior of the stand B and serves to prevent the tool-post from turning round. The tool-post is hollow, and it is provided with an internal screw-thread, *b*, which engages with a screw-thread, *c*, formed on the hub *d* of a bevel-wheel, C, which bears upon the surface of the slide-rest, on which the stand B is secured. The bevel-wheel C gears into a pinion, D, which is mounted on the inner end of a horizontal shaft, E, that has its bearing in the side of the stand B. The outer end of the shaft E is square, so that a handle can be applied for turning the same. By turning said shaft the bevel-wheel C is caused to revolve, and by the action of the screw-thread *c* on the hub *d* and of the screw-thread *b* in the interior of the tool-post said tool-post is moved up or down in the socketed stand B, the feather-key *a* preventing the same from turning round. The stand B is split open on one side, and provided with a clamping-screw, F, for the purpose of compressing the stand B and causing it to hug the tool-post firmly.

In the example represented by the draw-

ings, a turning-tool, G, is secured in the slotted revolving post H by the clamping-screw I. The post H is held up by a spiral spring, J, located in a cavity of the hub *d*.

It will be readily seen that by applying a suitable handle or key to the horizontal shaft E the tool G can be raised or lowered while it is in operation, the shaft E being in such a position that the key used for turning the same can be manipulated without coming in contact with the work, or with any portion of the tool-post or the parts connected to the same.

If desired, an emery-wheel or a milling-tool can be secured on the top of the tool-post A. In this case the revolving post H must be removed, so that the frame in which the emery-wheel or milling-tool is mounted can be screwed down upon the surface of the tool-post.

If my tool-post is used in combination with tools of this class, the great convenience of my mechanism for raising and lowering the tool-post will be fully appreciated by skillful mechanics.

I am aware that a tool-post has heretofore been constructed which can be raised and lowered by means of a rack formed on the tool-post, and a vertical worm mounted on the stand and gearing into the rack. This device, however, cannot be used (except with great inconvenience) for adjusting the tool while the same is in operation.

What I claim as new, and desire to secure by Letters Patent, is—

The combination of the socketed stand B with the tool-post A, connected with each other to prevent rotation of the post, the bevel-wheel C, having the screw-threaded hub *d* engaging the internal screw-threads *b* of the tool-post, with the vertical bevel-pinion D, and its horizontal operating-shaft E, all constructed and arranged to operate substantially as shown and described.

In testimony whereof I have hereunto set my hand and seal in the presence of two subscribing witnesses.

CHARLES A. LIEB. [L. S.]

Witnesses:

W. HAUFF,  
OTTO HUFELAND.